

Landing light Type 480 "Helios"



Light for helicopter landing pads suitable for night vision devices (NVG). A grid limits the light very strongly upwards so that the pilot is not dazzled during approach. This light is available with LED. Due to the low overall height of 180mm, the floodlight does not represent an obstacle on the platform or on the ground according to BAZL guideline AD I-012D.

Additional infrared LED are installed in the landing light. Thus the light is night vision compatible (NVG).

The light was designed according to the recommendations of REGA.

Technical Data

Casing	Aluminium casting
Glasses	Polycarbonate (LED)
Weight	12kg
Source of light	LED white incl. IRD
Temperature	LED -20°C to +50°C
Protection	IP 65
Cable input	Cable gland M20 x 1.5
Connection	using silicone cables
Mounting	using three latches or three M8 threads in the base

Power input

	55W LED
230V AC	0.24A

Execution and Accessory

Glasses	Clear front Position yellow or without Other glass colors on request
Options	Safety guard

Order Information

Order number	480a-WH-cc-230-750
Execution (a)	S with safety guard L LED version
Position glass (cc)	YE yellow, GN green (EU version), 00 without glass top
Voltage	230 230V AC

Front view

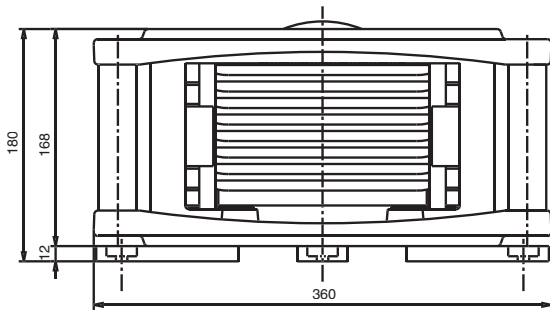

Side view

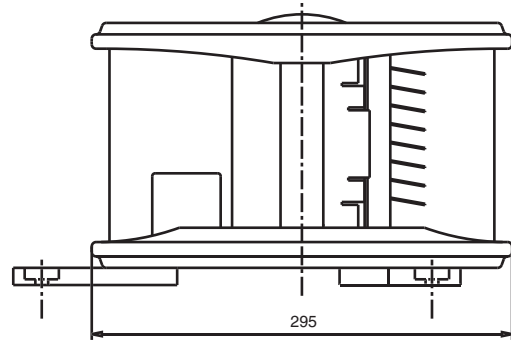

Top view

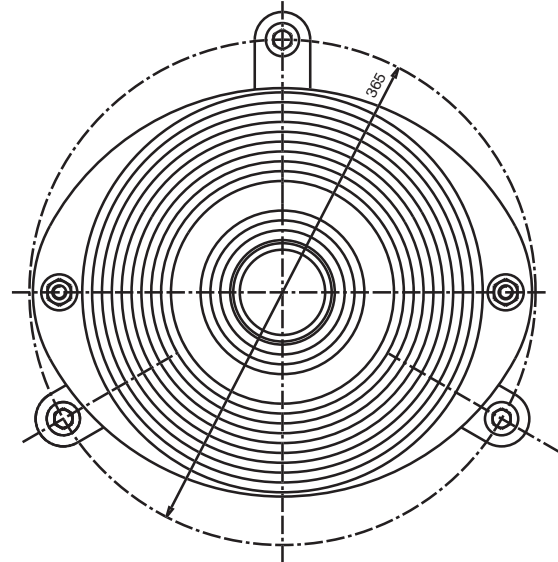

Hugentobler Spezialleuchten AG

Brunnenwiesenstrasse 14

CH - 8570 Weinfelden

Tel. +41 71 626 20 40

info@spezialleuchten.ch

www.spezialleuchten.ch



Signalling and alarm lights



Special lights for aviation and navigation



Tunnel safety lights