

Approach light Type 432 Vers.2

Approach lights for the signalisation of heliports (e.g. hospitals). The flashing beacon is particularly suitable for landing sites without additional visual guidance or with strong ambient light. The approach light is also suitable for night vision (NVG).

Additional functions:

- selectable light sequences
- light source monitoring
- surge protection
- Exchangeable modular components (incl. LED)

The light meets the requirements of ICAO 14, Volume II.



Technical Data

Casing	Aluminium/VA2/glass
Protection	IP 67
Weight	from 9.2kg
Source of light	High Powered LEDs
Light intensity	2500cd
Mounting	4 screws
Voltage	230V AC 12 & 24V DC
Performance	51 - 66W
Temperature	-55°C to +55°C

Power input

96-264V AC	0.50A
12V DC	8.60A
24V DC	4.30A

Accessory

Options:

- Programmable version
- Radio remote control
- GPS, wind measurement module
- Synchronisation module

Order Information

Order number	432-c-uuu-zz
Color code (c)	R red W white G green Y yellow
Voltage (uuu)	Voltages with leading zeros
Options (zz)	M Morse code ICAO MA Morse code ICAO/Alarm H Heliport 3 colors HA Heliport/Airport 2 colors

Side view



Length: 31 cm

Width: 31 cm

Height: 25 cm

Bottom view

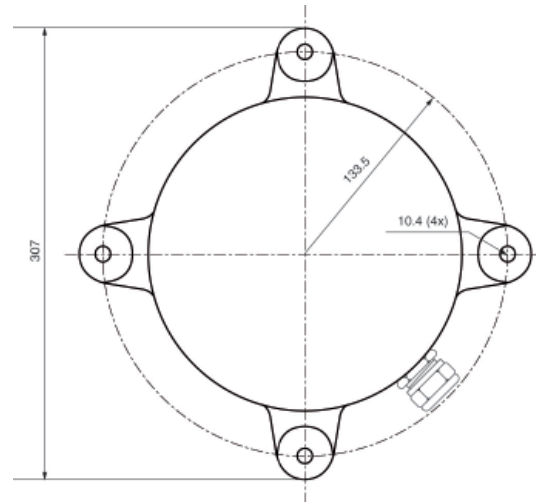

Hugentobler Spezialleuchten AG

Brunnenwiesenstrasse 14

CH - 8570 Weinfelden

Tel. +41 71 626 20 40

info@spezialleuchten.ch

www.spezialleuchten.ch



Signalling and alarm lights



Special lights for aviation and navigation



Tunnel safety lights