

# Solar Port entrance lantern, Type M860

Light-intensive and maintenance-free solar lantern for marking port entrances and maritime obstacles.

Absolutely waterproof and UV-resistant.

The bird deterrent is included in the delivery.



## Technical Data

<b>Casing</b>	Plastic
<b>Protection</b>	IP 68
<b>Weight</b>	6.4kg
<b>Source of light</b>	High Powered LEDs
<b>Temperature</b>	-30°C to +50°C
<b>Mounting</b>	by using 3, 4 or 5 screws
<b>System autonomy</b>	350 hours (flashing)
<b>Battery</b>	can be replaced
<b>Visibility</b>	approx. 5.56km to 11.11km
<b>Beam angle</b>	8° (horizontally) 360° (vertically)

## Accessory

- Programming device
- Safety bolt
- Base
- Support tube
- Wire guard

## Order Information

<b>Order number</b>	860-cc		
<b>Color code (cc)</b>	WH white,	YE yellow,	
	RD red,	GN green	

### Side view

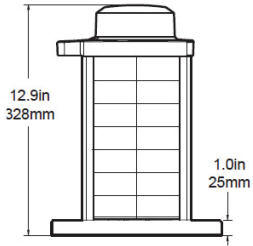

### Bottom view

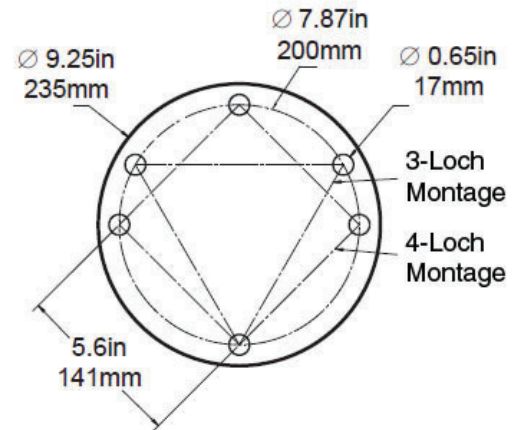

**Hugentobler Spezialleuchten AG**

**Brunnenwiesenstrasse 14**

**CH - 8570 Weinfelden**

**Tel. +41 71 626 20 40**

**info@spezialleuchten.ch**

**www.spezialleuchten.ch**



**Signalling and alarm lights**



**Special lights for aviation and navigation**



**Tunnel safety lights**