

Solar lantern Type M660

This uncomplicated solar lantern is durable, waterproof, UV-resistant and maintenance-free. The LEDs ensure good visibility.

For temporary marking of port entrances and maritime obstacles.

Various mounting options. Also suitable for mounting on a pole with \varnothing 70 or \varnothing 72.

The bird deterrent is included in the delivery.

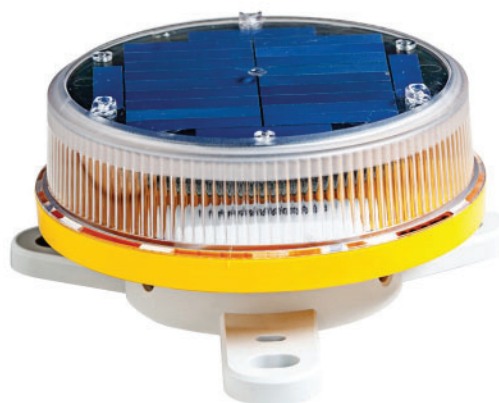

Technical Data

Casing	Plastic
Protection	IP 68
Weight	0.8kg
Source of light	High Powered LEDs
Temperature	-40°C to +50°C
Mounting	by using 3 screws
Battery	Li-ions (IEC 61233), replaceable, 19Wh / 38Wh
Visibility	up to 7.4km (4 NM)
Beam angle	360° (horizontally) > 8° (vertically)

Accessory

- Base (inkl. Screws)
- Programming device / APP
- Battery replacement pack
- Double battery replacement pack
- Battery charger

Options (not retrofittable)

- ON / OFF Switch
- Charging socket
- Double battery pack

Order Information

Order number	660-cc-op		
Color code (cc)	WH white,	YE yellow,	
	RD red,	GN green,	
	BL blue		
Options (op)	S	Switch	
	C	Charging socket	
	2B	Double battery pack	

Side view

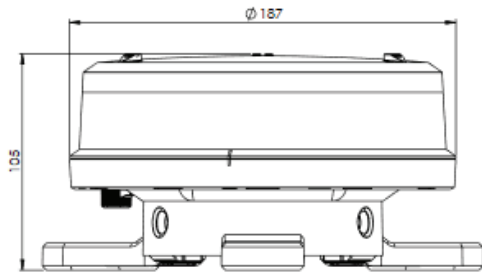

Bottom view

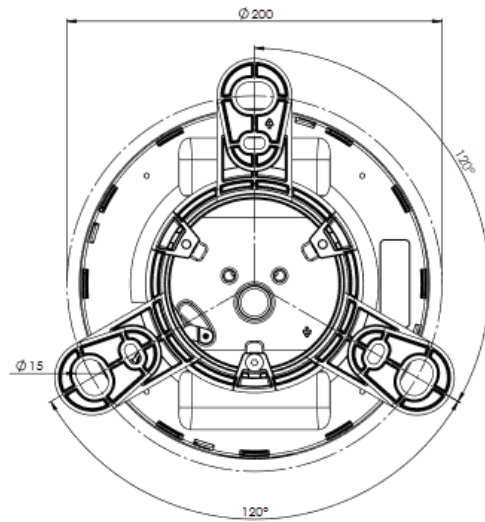

Hugentobler Spezialleuchten AG

Brunnenwiesenstrasse 14

CH - 8570 Weinfelden

Tel. +41 71 626 20 40

info@spezialleuchten.ch

www.spezialleuchten.ch



Signalling and alarm lights



Special lights for aviation and navigation



Tunnel safety lights