

LED Obstruction Light Type 426

High impact and weather-resistant obstruction light according to the regulations of the Federal Office for Civil Aviation BAZL (AD I-006) as well as ICAO (Annex 14, Chapter 6). For marking **aviation obstacles with low intensity obstruction lights; e.g. high-rise buildings or construction cranes.**

A red light (RD) and an infrared light (IR) are installed in this product. Thus, it is suitable for night vision devices (NVG). The red light shines permanently, the infrared light flashes. Thanks to GPS-synchronisation, several lights flash simultaneously.

Simple clamp mounting of the light, e.g. on a tube.



Technical Data

Casing	high impact polycarbonate
Protection	IP 67
Weight	1.35kg
Light source	LED
Mounting	clamped to tube
Voltage	12V DC 24V DC 110-230V AC
Light intensity	RD 12 cd red light IR > 150 mW _{sr} infrared light
Color location	red light 623nm infrared light = 850nm
Flash frequency	red light: permanent infrared light: flashing, 20 pulses/min. 0.5s ON, 2.5s OFF

Maximum power input

	Type 426
12V DC	320mA
24V DC	220mA
230V AC	47mA

Execution and Accessory

Execution	with error monitoring with flash frequency synchronisation for multiple lights of the same system
Accessory	3/4" adapter twilight control, external bracket with tube and cable tie magnetic holder with safety rope marker balloon alternative flash frequencies

Order Information

Order number	426-uuu-RIR-R-GPF
Voltage (uuu)	012 12V DC 024 24V DC 230 230V AC
Color code	RIR red / Infrared
Monitoring	R with relay contact for error monitoring
Execution	GPF synchronisation of flash frequency

Front view

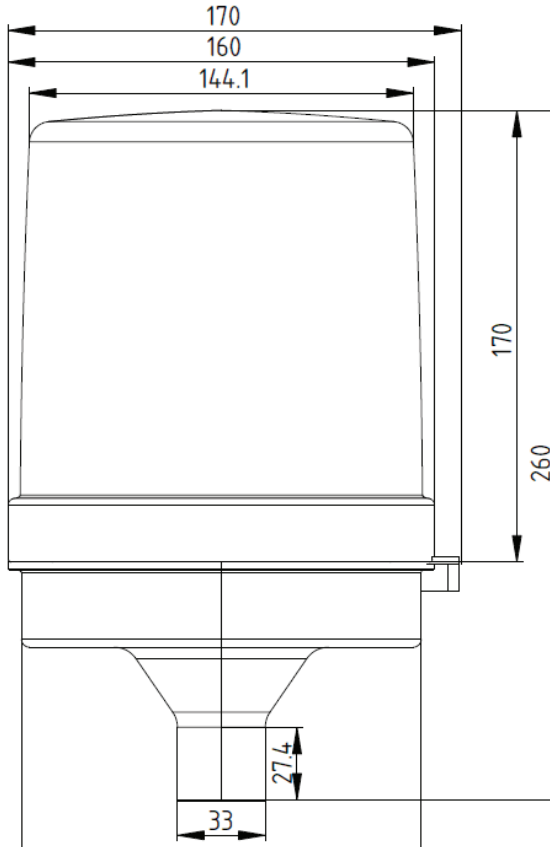

Top view

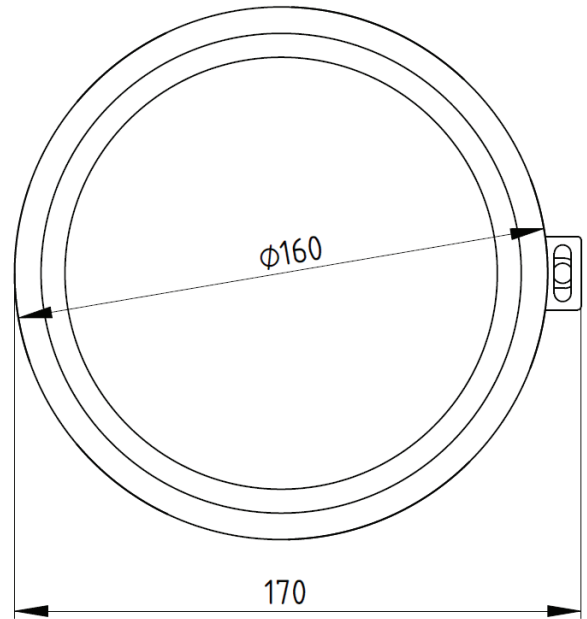

Bottom view

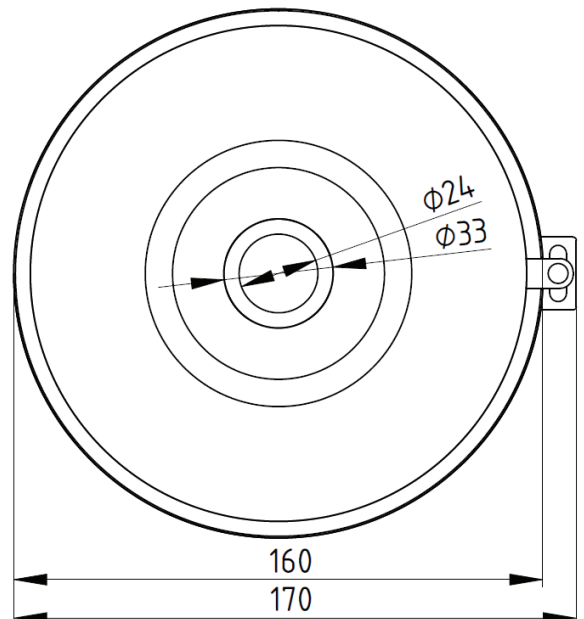

Hugentobler Spezialleuchten AG

Brunnenwiesenstrasse 14

CH - 8570 Weinfelden

Tel. +41 71 626 20 40

info@spezialleuchten.ch

www.spezialleuchten.ch



Signalling and alarm lights



Special lights for aviation and navigation



Tunnel safety lights