

Solar lantern Type M660

Sturdy solar light with battery pack for temporary marking of port entrances and maritime obstacles. The built-in battery is designed for maintenance-free operation. The battery capacity and active load control ensure reliable operation over several days, even with little sunshine and/or long periods of fog.

The light is switched on and off via the integrated twilight switch. Continuous light or various flashing frequencies and intensity levels enable visibility ranges of between 2 and 3 nautical miles. It is configured ex works in accordance with requirements. After installation, the parameters can be adjusted via Bluetooth® or the separately available programming device if required.

The housing and lens are made of plastic.

A bird deterrent is included in the scope of delivery.

Technical Data

Casing	Polysiloxanes, UV-resistant
Lenses/light emission	Polycarbonate, UV-stabilised
Protection	IP 68
Weight	0.8kg
Source of light	high performance LED
Mounting	3 screws, M10
Visibility	2 - 3 NM (TC=0.74)
Beam angle	360° (horizontal) 8° (vertical)
Maximum intensity with fixed light	red 40 cd green 42 cd yellow 52 cd white 71 cd
Voltage	1 2.5W high performance solar cell with MPPT controller 43.62Wh battery / 3.6V / 12Ah (replaceable by Hugentobler Spezialleuchten AG) 1 ON/OFF switch
Power consumption	n/a
Temperature	-30°C to +50°C
Configuration	by Bluetooth® by programming device (accessory)

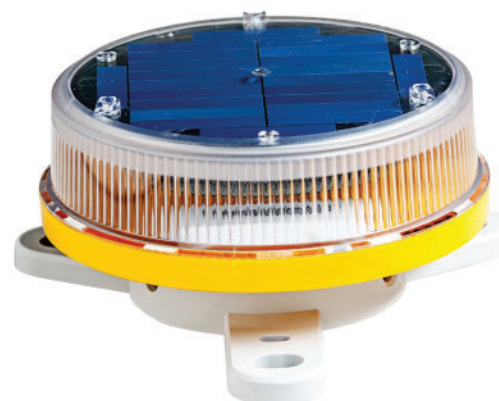

Execution and Accessory

Options	none
Accessories	- programming device - bird deterrent

Order Information

Order number	M660cc-2B
Color code (cc)	RD red GN green YE yellow WH white
Execution (2B)	double battery pack

Side view

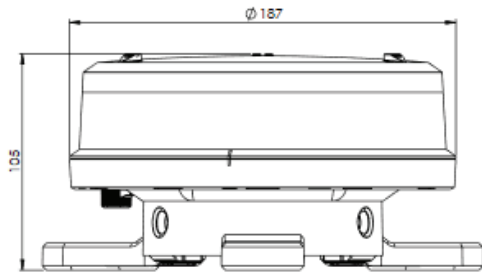

Bottom view

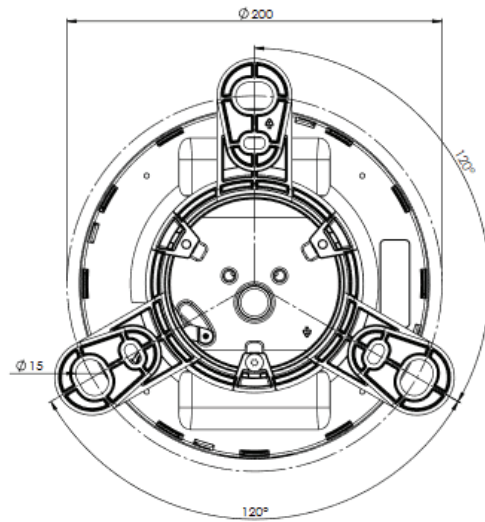

Hugentobler Spezialleuchten AG

Brunnenwiesenstrasse 14

CH - 8570 Weinfelden

Tel. +41 71 626 20 40

info@spezialleuchten.ch

www.spezialleuchten.ch



Signalling and alarm lights



Special lights for aviation and navigation



Tunnel safety lights